

MAXIMUM WEIGHT	
PER SHELF	30 (kg)

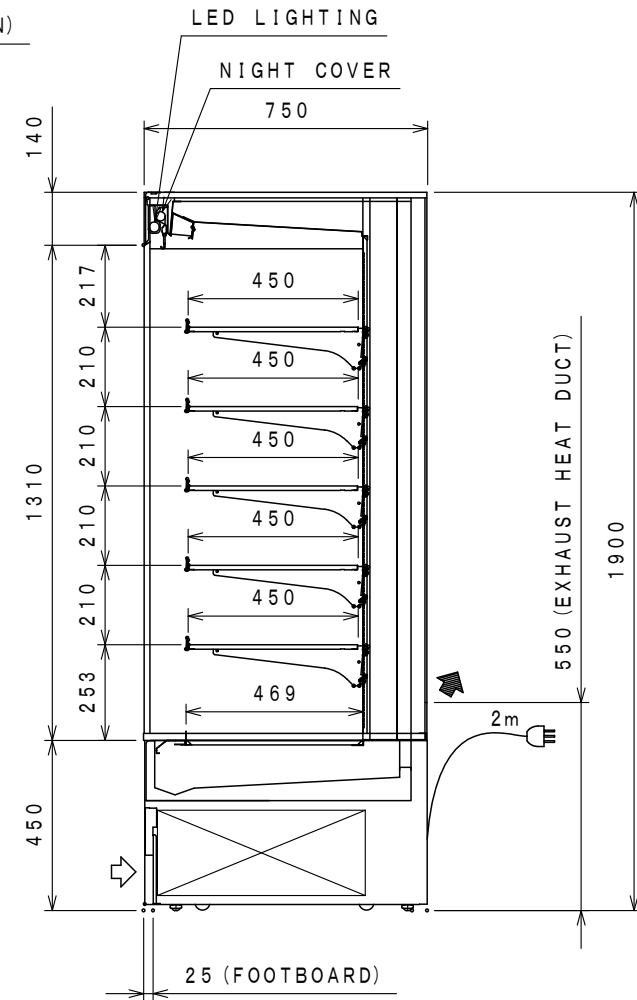
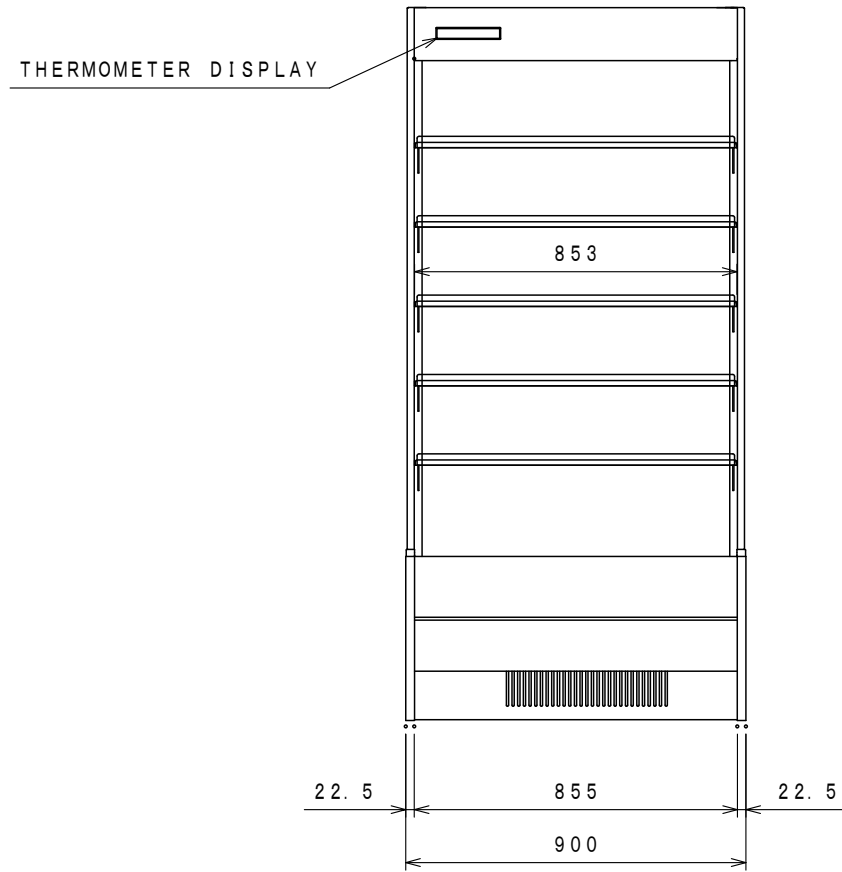
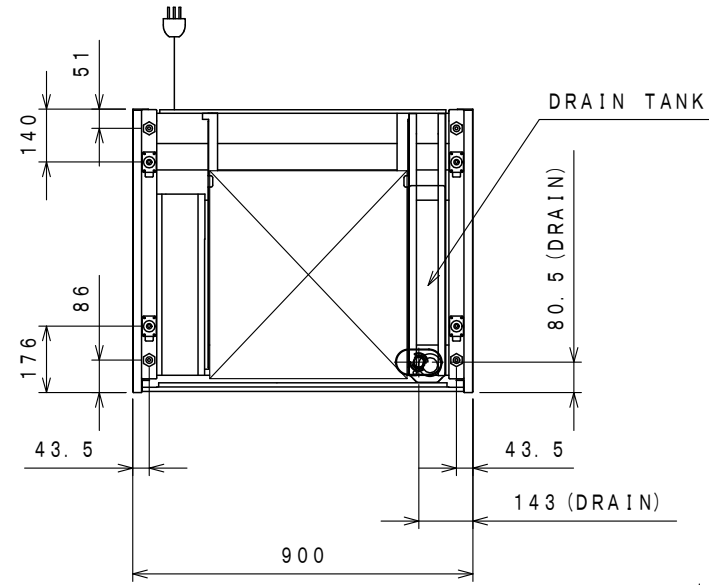

PRODUCT NAME	Commercial Refrigerator Showcase	
MODEL	MEK-3AGKJT5L-TH	
POWER SUPPLY	Single Phase 220V 50Hz	
OUTSIDE DIMENSIONS	(W) 900mm× (D) 750mm× (H) 1900mm	
INSIDE DIMENSIONS	(W) 855mm× (D) 469mm× (H) 1310mm	
EFFECTIVE CAPACITY	539L	
SHELF	Steel Plate Shelf (Variable 0° or 8°)	
DISPLAY AREA	2.31 m ²	
WEIGHT	200kg	
EXTERIOR MATERIAL	Color Steel, Painted Steel Galvanized Steel, Pair Glass Resin Molded Product	
INTERIOR MATERIAL	Color Steel, Painted Steel	
INSULATION MATERIAL	Polyurethane Foam	
AMBIENT AIR CONDITION	Temperature	27°C OR LESS
	Humidity	70% OR LESS
	Wind Speed	0.2m/s OR LESS
COOLING PERFORMANCE	3°C to 20°C (No Load and Within Ambient Air Condition)	
COMPRESSOR	770W (DC Inverter)	
REFRIGERANT CONTROL METHOD	Electronic Expansion Valve	
CONDENSER	Fin and Tube Type, Forced Air-Cooling	
EVAPORATOR	Fin and Tube Type, Forced Cold Air Circulation	
REFRIGERANT	R-404A	
TEMPERATURE CONTROL	Microcomputer Control, Digital Display	
DEFROST CONTROL	Microcomputer Control Offcycle Defrost	
APPLICABLE BREAKER CAPACITY	Single Phase 220V 15A 50Hz	
POWER CORD	2.0m (Plug with Earth Wire)	
VOLTAGE RANGE	220V±6%	
COOLING	Operation Current	2.9A
	Maximum Current	5.0A
	Power Consumption	600W
	Power Factor	93%
DEFROSTING	Operation Current	0.6A
	Power Consumption	87W
RADIATION OF HEAT CAPACITY	3050W	
ACCESSORIES	Alarm Buzzer (Standard Equipment) Night Cover Caster Drain Tank	
OTHER ACCESSORIES	Condenser Filter Internal Lighting (LED: 8.5W×1)	

⇨ SUCTION AIR
⇨ EXHAUST AIR

PLUG TYPE

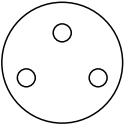

- Ambient temperature: 27°C, humidity: 70%, wind speed: 0.2 m/s or less
Discard the water in the drain tank once a day.
If the above installation conditions are exceeded, discard the water in the drain tank before the drain tank overflows.
- The back side unit will have a higher ambient temperature due to exhaust heat.
Please be careful about the display of surrounding products
- We may change it without a notice for improvement about the specifications and design.

		REFERENCE NO
DATA 05 . 04 . 2021	SCALE 1/20	DRAWING NO

GALILEI (THAILAND) CO., LTD.