

DRAIN HOSE 2000mm
(OUTSIDE DIAMETER $\phi 25$)

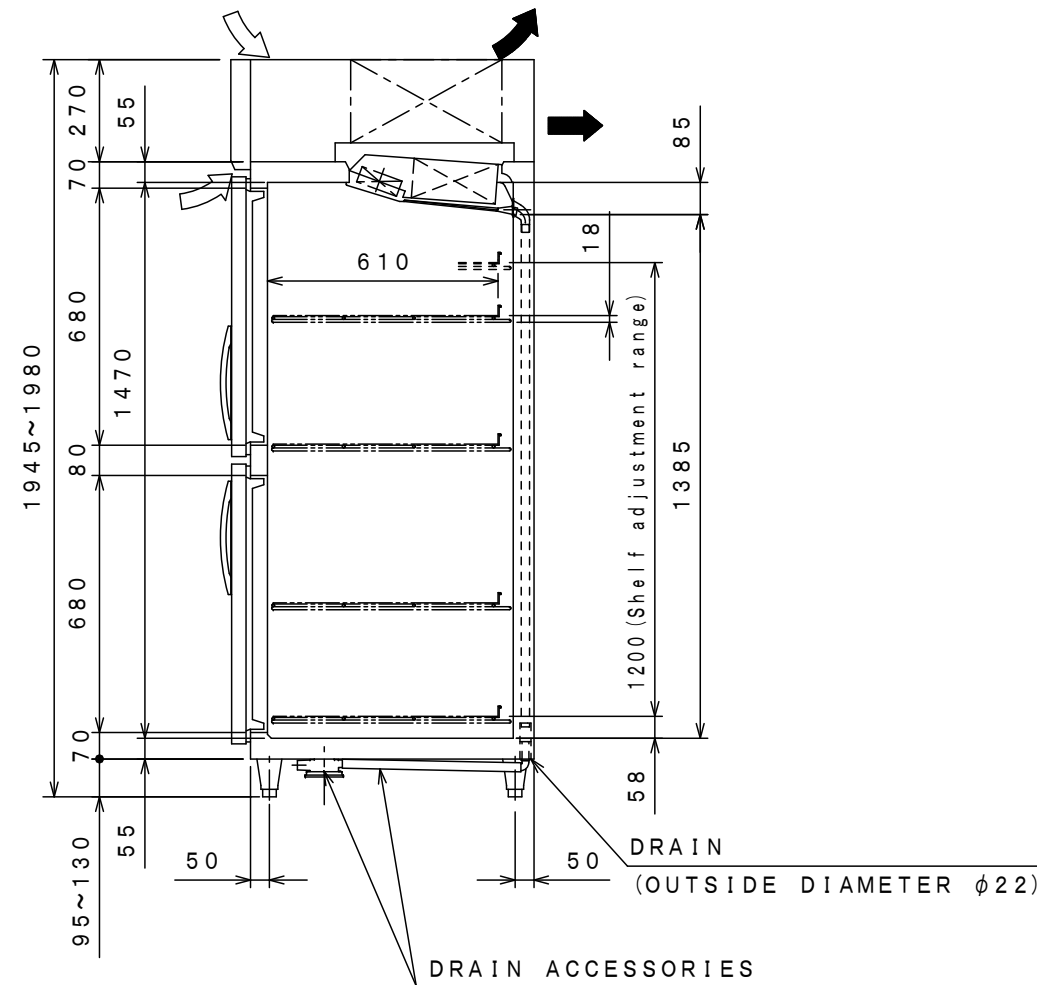

PRODUCT NAME	Commercial Freezer (Upright Type)	
MODEL	URD-154FMC-TH	
POWER SUPPLY	Single Phase 220V 50Hz	
OUTSIDE DIMENSIONS	(W) 1490mm x (D) 800mm x (H) 1950mm	
INSIDE DIMENSIONS	(W) 1390mm x (D) 650mm x (H) 1470mm	
EFFECTIVE CAPACITY	1372L	
WEIGHT	160kg	
EXTERIOR MATERIAL	Stainless Steel (Front and Sides) Galvanized Steel (Top) Galvanized Steel (Rear and Bottom)	
INTERIOR MATERIAL	Stainless Steel	
DOOR MATERIAL	Stainless Steel (Front) ABS Resin, Magnet-Style Packing (Rear)	
INSULATION MATERIAL	Polyurethane Foam	
ADJUSTABLE SHELF MATERIAL	Steel Wire Resin coating	
COOLING PERFORMANCE	-25°C to -15°C (No Load and Ambient Temperature of 30°C)	
COMPRESSOR	425Wx2	
REFRIGERANT CONTROL METHOD	Capillary Tube	
CONDENSER	Fin and Tube Type, Forced Air-Cooling	
EVAPORATOR	Fin and Tube Type, Forced Cold Air Circulation	
REFRIGERANT	R-404A	
TEMPERATURE CONTROL	Microcomputer Control, Digital Display	
DEFROST CONTROL	Microcomputer Control Defrost Heater	
APPLICABLE BREAKER CAPACITY	Single Phase 220V 15A 50Hz	
POWER CORD	2.0m (Plug with Earth Wire)	
VOLTAGE RANGE	220V \pm 6%	
COOLING	Operation Current	3.5A
	Starting Current	20A
	Power Consumption	725W
DEFROSTING	Operation Current	2.3A
	Power Consumption	503W
OPERATING TEMPERATURE RANGE	5°C to 35°C	
RADIATION OF HEAT CAPACITY	1410W	
ADJUSTABLE LEG	Resin made Leg form 95 to 130mm	
ACCESSORIES	Shelves (8 Pieces) Drain Accessory (1 Set)	
OTHER ACCESSORIES	Condenser Filter	

We may change it without a notice for improvement about the specifications and design.

◁ SUCTION AIR
▶ EXHAUST AIR

PLUG TYPE

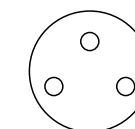

		REFERENCE NO
DATA 18 . 10 . 2022	SCALE 1/20	DRAWING NO

GALILEI (THAILAND) CO., LTD.